



PETKUS Chemical Seed Treater Type CT (Coating Machines) are suitable for various liquid and slurry chemical products.

Treating applications:

- Most seed types including wheat, barley, oats and cotton
- Other specialty seeds such as canola, sugarbeet etc.

The PETKUS Chemical Seed Treater is an efficient universal machine fully tested for use with approved liquid and slurry chemicals. The compact design allows the machine to be easily installed in most seed plants.

Advantages:

- Continuous and reliable operation.
- Easy handling and adjustment of the machine.
- Undoubtedly and homogenous mixing operation due to precise primary distribution of the chemical and effective mixing in the secondary mixing unit.
- Precise dosing of the liquid chemical (i.e. based on manufacturer recommended volume).
- Fine spraying of the chemical by use of the spraying disc, no blockage.
- Uniform distribution of the chemical on the seed corn based on multiple and careful contact with the chemical liquid.
- Incorrect treatment of seed corn will be avoided due to integration of automatically control system by sensors.
- Preventing of intermixing in case of change of the seed products based on complete empty run of the machine and self cleaning function.
- Solid and rigid construction of the machine
- Totally closed construction
- Equipment with various type of pumps and 2 or 3 pumps for different chemicals.
- Stainless steel for parts which are in touch with the chemical product.

Flow diagram

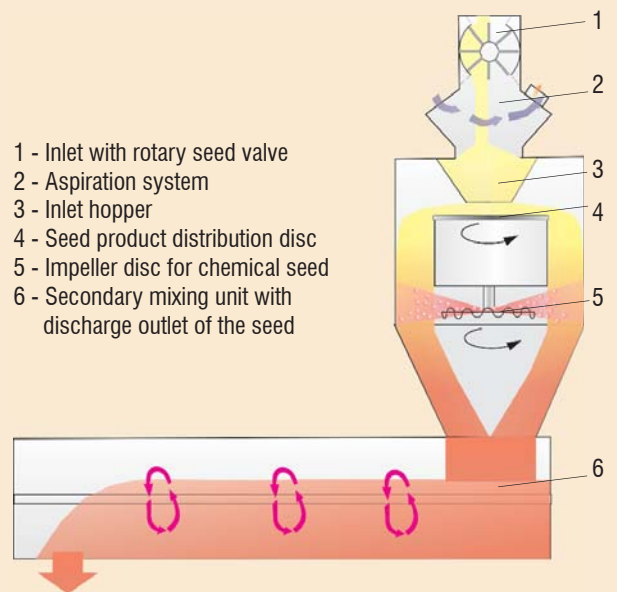

- 1 - Inlet with rotary seed valve
- 2 - Aspiration system
- 3 - Inlet hopper
- 4 - Seed product distribution disc
- 5 - Impeller disc for chemical seed
- 6 - Secondary mixing unit with discharge outlet of the seed

Operation process:

The seed is flowing through the inlet buffer by passing the rotary seed valve and wind aspiration into the treater machine. With the seed spraying disc the seed will be distributed in an uniform product veil. The chemical is feed into the treater by the pump and the chemical feeding system. The chemical liquid is distributed to the seed product by the rotating Impeller disc. In the secondary mixing unit the seed will be transported and it starts an intensive mixing with the chemical.

Type variety:

- Chemical seed treater Type A - without rotary seed valve,
- Chemical seed treater Type B - with rotary seed valve,

Option of electronically control systems:

- SPS Simatic S7 - 200 Control System with Touchpanel
- SPS Simatic S7 - 200 Control System with Key panel TD100C
- Control System Type LOGO

The success of a good chemical treatment depends on:

- Proven chemical formulation
- Highly developed chemical seed treater
- High quality seed

Chemical Seed Treater Type CT 5-25

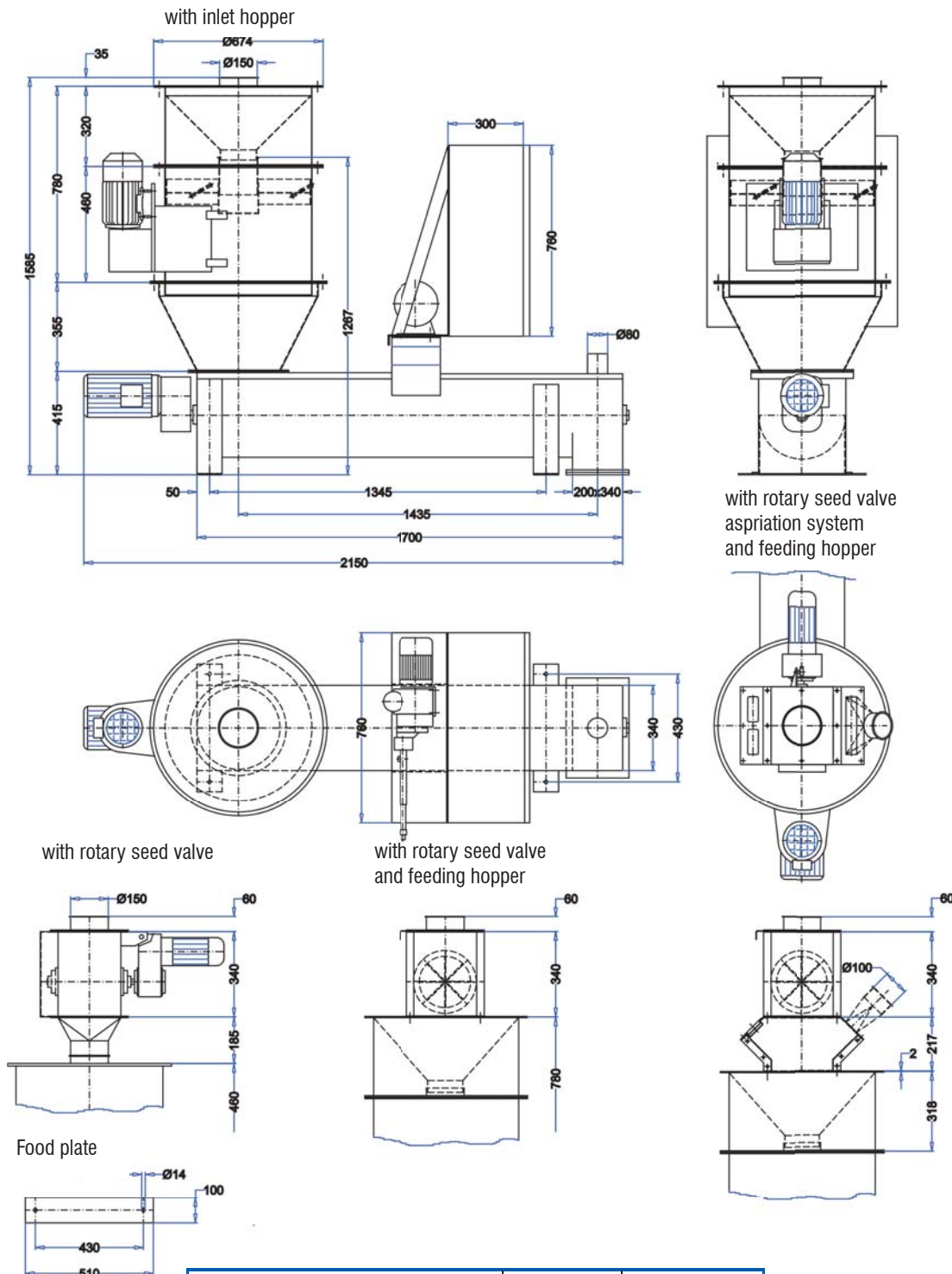

Technical data		CT 5-25
Capacity (Based on Wheat)	t/h	5 to 25
Electrical drives		
Distribution disc	kW	0,75
Cleaning unit, (option)	kW	0,18
Secondary mixing unit	kW	1,5
Pump	kW	0,37/0,55
Rotary seed valve	kW	0,37
Dosing of chemical liquid	ml/100kg	200 - 800

Technical Alteration reserved.