

Design RB 500 / RB 650

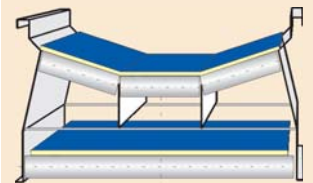

Design RB 800

PETKUS Belt conveyors are well suitable for the conveyance of bulk material in the agriculture and industry, like cereals, oil seeds, pulses, as well as for the transport of products in powder form.

Standard equipment:

- Tension station,
- Inlets,
- Outlets,
- Material galvanised steel sheet, wall thickness of the standard casings 2,5 - 3 mm,
- Driving station, drive of the belt conveyor with direct connected gear motor,
- Belt width, available in 500, 650 and 800 mm,
- Intermediate casing length standard casing length 2,0; 2,5; 3,0 m
- Belt velocity, standard belt speed is 1,5 m/s. Other speeds available due to customers request.

Conveying capacity: (Dimensioning: 0,75 t/m³)

RB 500 up to 60 t/h
RB 650 up to 100 t/h
RB 800 up to 150 t/h

Optional equipment:

- Top cover sheets,
- Belt tripper conveyor, variable, one and two sides,
- Bottom cladding,
- Belt controlling,
- Stainless steel version.

Belt conveyor Type RB 500 / RB 650 / RB 800

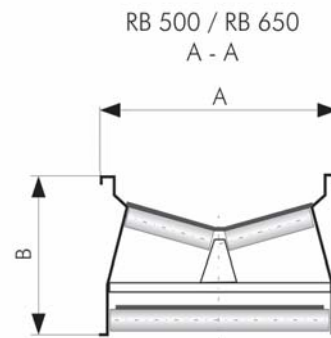
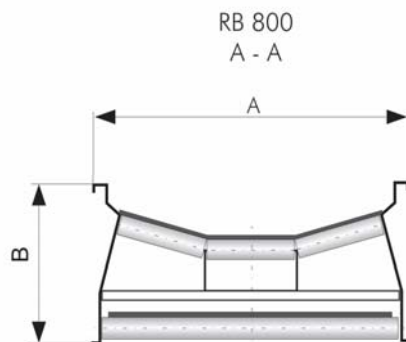
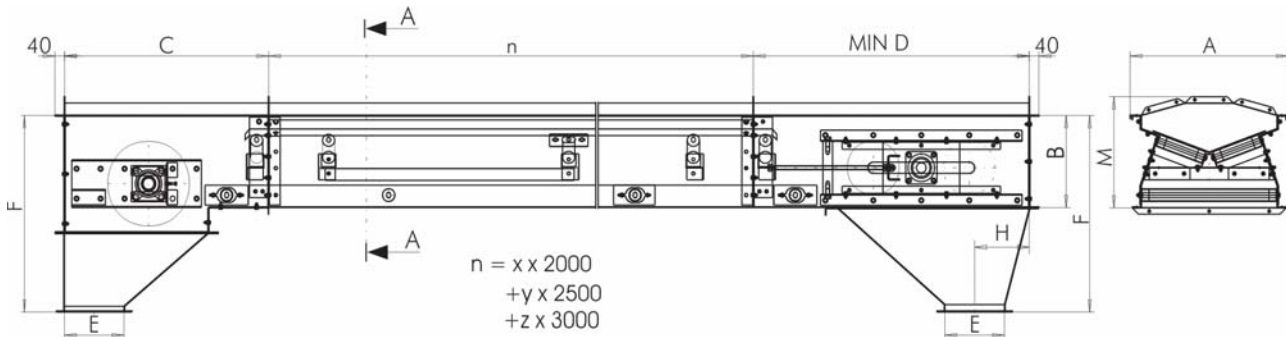

Type	Belt width	A	B	C	D	E (NW)	F	H	M
RB 500	500	660	410	1000	1150	250	910	267,5	486
RB 650	650	800	435	1100	1300	250	910	295	523
RB 800	800	950	410	1250	1350	300	990	295	510

Type			Belt speed m/s	Transport rolls			Back rolls	
	m ³ /h	t/h 0,75t/m ²		Diameter mm	Distance mm	Diameter mm	Distance mm	
RB 500	80	60	1,5	2 Rolls 20°	51	1000	51	2000
RB 650	134	100	1,5	2 Rolls 20°	51	1000	51	2000
RB 800	200	150	1,5	2 Rolls 20°	63,5	1000	63,5	2000

Technical Alteration reserved.